

EM-FINITY CLOSURE

Your Closure, Your Way. **Connect Beyond Limits**

1056+ splices / 96 LC Pre-connectorized customers

Modular Splice Closure System

- Fully Customizable
 - Color Coded
 - Custom Fitted
 - 4 Sizes



INTRODUCING

Another innovation by Emtelle



The Premier Solution for Seamless Network Expansion

EM-Finity enhances the traditionally complex process of network expansion into a streamlined, efficient, and straightforward experience. Our design simplifies expansion, significantly reducing both time and resource expenditure.

Moreover, EM-Finity sets a new benchmark for quality and reliability in splice closures, a critical component of drop networks. Our extensive testing guarantees superior performance and durability, ensuring that your investment delivers long-lasting value.

The intuitive, color-coordinated design of EM-Finity facilitates easy network management and adaptability to future demands, providing you with the confidence to meet evolving technological requirements.

EM-Finity Sustainable Benefits

The color-coded system speeds up installation and management, reducing time, resources, translating into less environmental impact. The modular design allows for easy upgrades, and its energy-efficient manufacturing process cuts carbon emissions. Additionally, the compact design reduces fuel use in transport, and our efficient distribution strategy cuts emissions from transportation.

Dual Purpose

Mechanical seals can be used for both duct & cable.

Modular System

Customizable and upgradable to meet your exacting requirements.

Lift & Lock System

Quick release clamp with locking option.

One Tray - Multiple Uses

A standard tray with 12 splices can also hold 2 splitters, efficiently combining both functions in a single unit.

Industry Leading Material

Constructed from high quality, corrosion resistant materials.



KEY BENEFITS

Definition of Simplicity

Our solutions combine ease of use with advanced functionality, ensuring a streamlined, future-ready network.

Tailored To Your Needs

Designed to fit your exact specifications, ensuring seamless integration and superior network performance.

Color Coded Management System

From color coded port entries, trays and pre-connectorized adapter ports. Emtelle's color coded cable management system allows you to manage your network from start to finish.

Upgradable System

Allowing more splice tray capacity, perfect for future network growth.

Versatile Solution

One closure designed for both mechanical (gel) and heat-shrink cable or microduct entries.

Quick and easy fiber management between each side of the closure, with a safe and innovative cable slack storage basket that is retained in the middle of the closure.

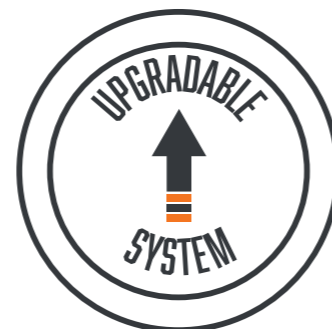

Disclaimer: EM-Finity can only be used in certain countries that support overhead networks.

SIZES FOR ANY APPLICATION

With fiber networks growing and expanding every day worldwide, EM-Finity can grow as your **future fiber** capacity grows.

There are 4 standard EM-Finity sizes - S, M, L and Lite, which can give you a wide range of splicing and patching options to meet your network build needs for now and the future.

EM-FINITY CLOSURES

Model	Approx Size (W x L)	Splice Capacity	Max Pre-Con Capacity	Trays Per Dome	Total Splice Capacity
Lite	185 x 390mm	24 per tray	24 LC / APC 12 SC / APC	6	144
Small	285 x 388mm	12 per tray	48 LC / APC 24 SC / APC	24	288
Medium	285 x 512mm	12 per tray	96 LC / APC 48 SC / APC	56	672
Large	285 x 635mm	12 per tray	96 LC / APC 48 SC / APC	88	1056

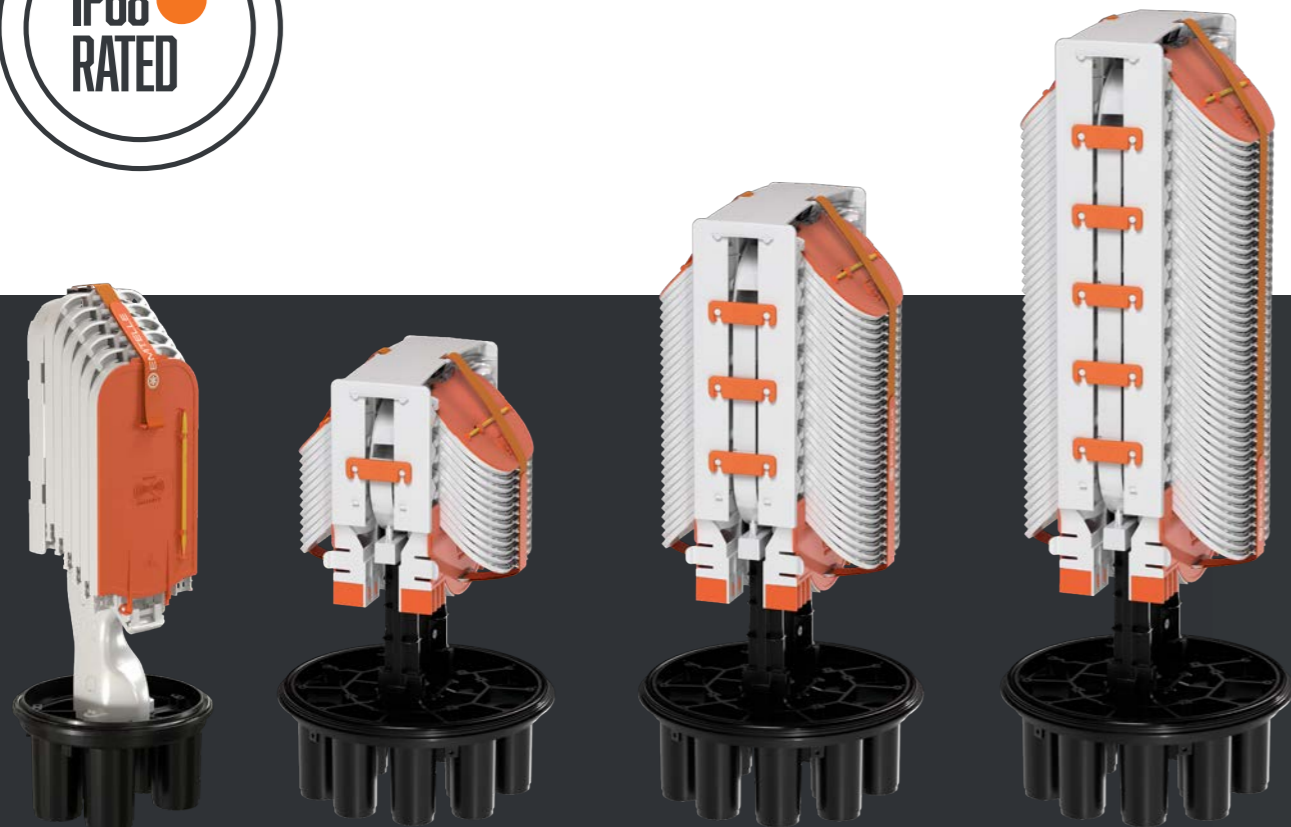

FIBER INSTALLATION WITH A COLOR-CODED SYSTEM

EM-Finity takes simplicity and efficiency to the next level with its **colored system**. Extending from colored port entries to corresponding trays. Traceability of fiber is greatly improved as a result of these features.

This color-coded design transforms the installation into a seamless and quick task, allowing for easy identification at a glance. The benefits extend beyond installation; the color-coded system ensures ongoing simplicity throughout the network. Adhering to recognized standards becomes self-explanatory for technicians, minimizing errors and streamlining maintenance.

- Reduce Errors ✓
- Simplify Record Keeping ✓
- Accelerate Fault Detection ✓

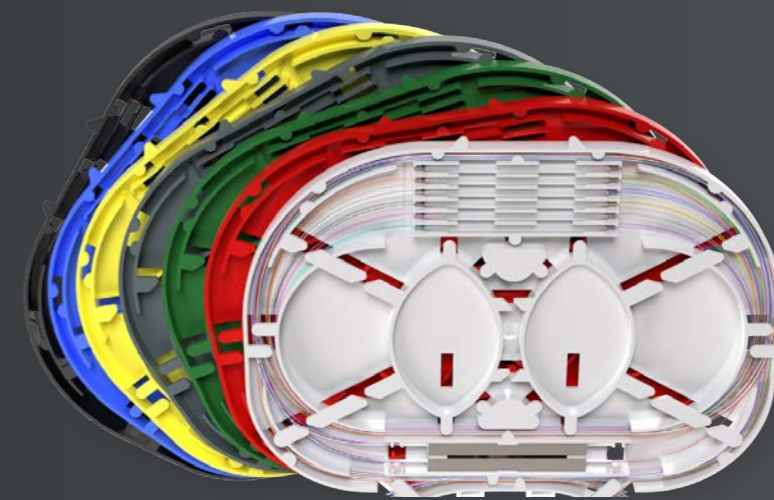
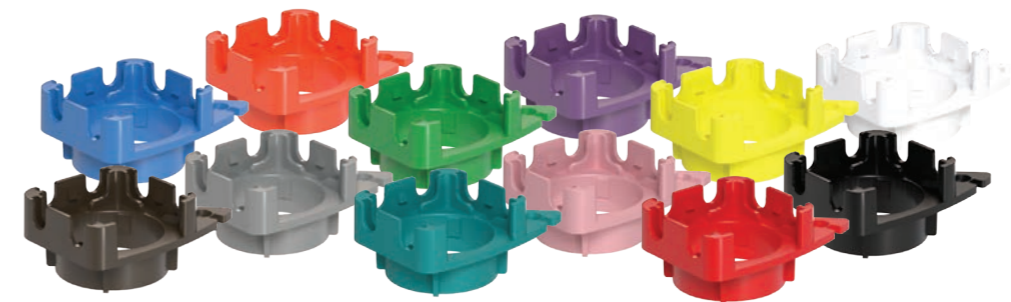

PRE-CONNECTORIZED

EM-Finity is your ticket to unmatched efficiency and flexibility for a seamless integration process - a **pre-connectorized** option for ultimate ease is offered as part of the range.

Mix-and-Match Flexibility: With the Pre-Connectorized EM-Finity, you can customize your closure to suit your needs. Whether you require partial or complete pre-connectorization, we've got you covered. This is not just a one-size-fits-all solution, but a solution that can be tailor made to your exact requirements.

Choice of Connectors: We understand that every network is unique, so we offer pre-connectorization with either LC or SC/APC connectors. Whether you prioritize performance or compatibility, rest assured that our pre-connectorized solution will meet your requirements with precision.

Color-Coordinated Clips: Our priority is keeping your installation process organized and efficient. That's why we've gone the extra mile to color-coordinate the clips on our fiber adapter mounts—with our intuitive design; you can ensure a seamless installation process every time.

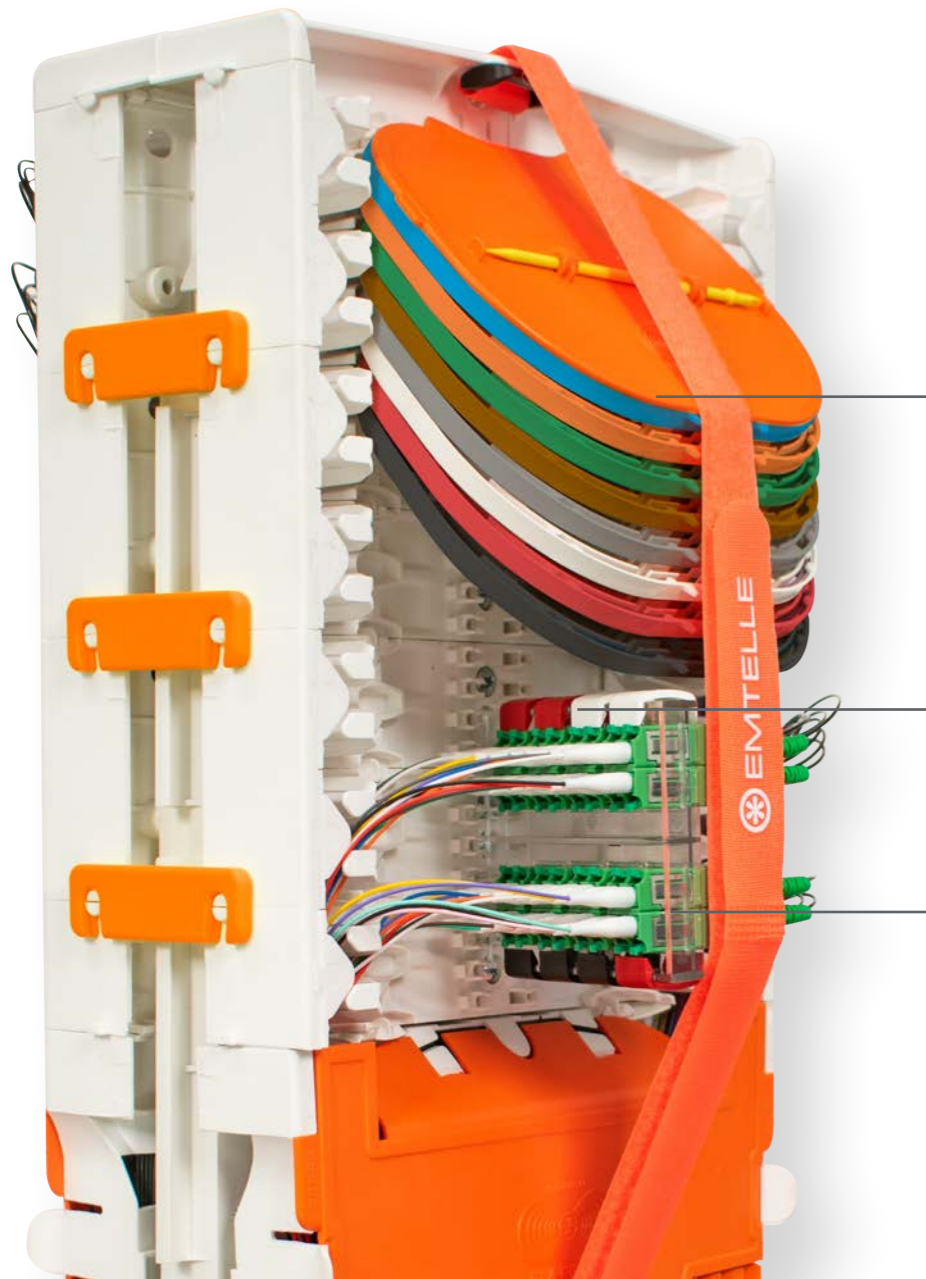

96 customer connections max.

Splitters or splice trays can accommodate PLC splitters, fusion splicing and ribbon splicing. With fiber management for front to back routing of the fibers.

Unique color coded fiber adapter mounts and colored pigtails makes installation and identification simple, quick and self-explanatory.

One modular fiber adapter mount can hold up to 32 customers.

Up to 96 individual drop ports available on the base.

MIX & MATCH

Have fiber splicing and pre-connectorized networks in **one closure**.

A closure that supports both fiber splicing and pre-connectorized solutions offers unparalleled flexibility, efficiency, and reliability. It streamlines deployment by accommodating different project requirements, reducing installation time, and minimizing costs. This versatility ensures scalability, simplifies maintenance, and future-proofs the network against evolving technologies. In essence, it combines the benefits of both methods to provide a versatile and future-ready solution for modern network deployments.

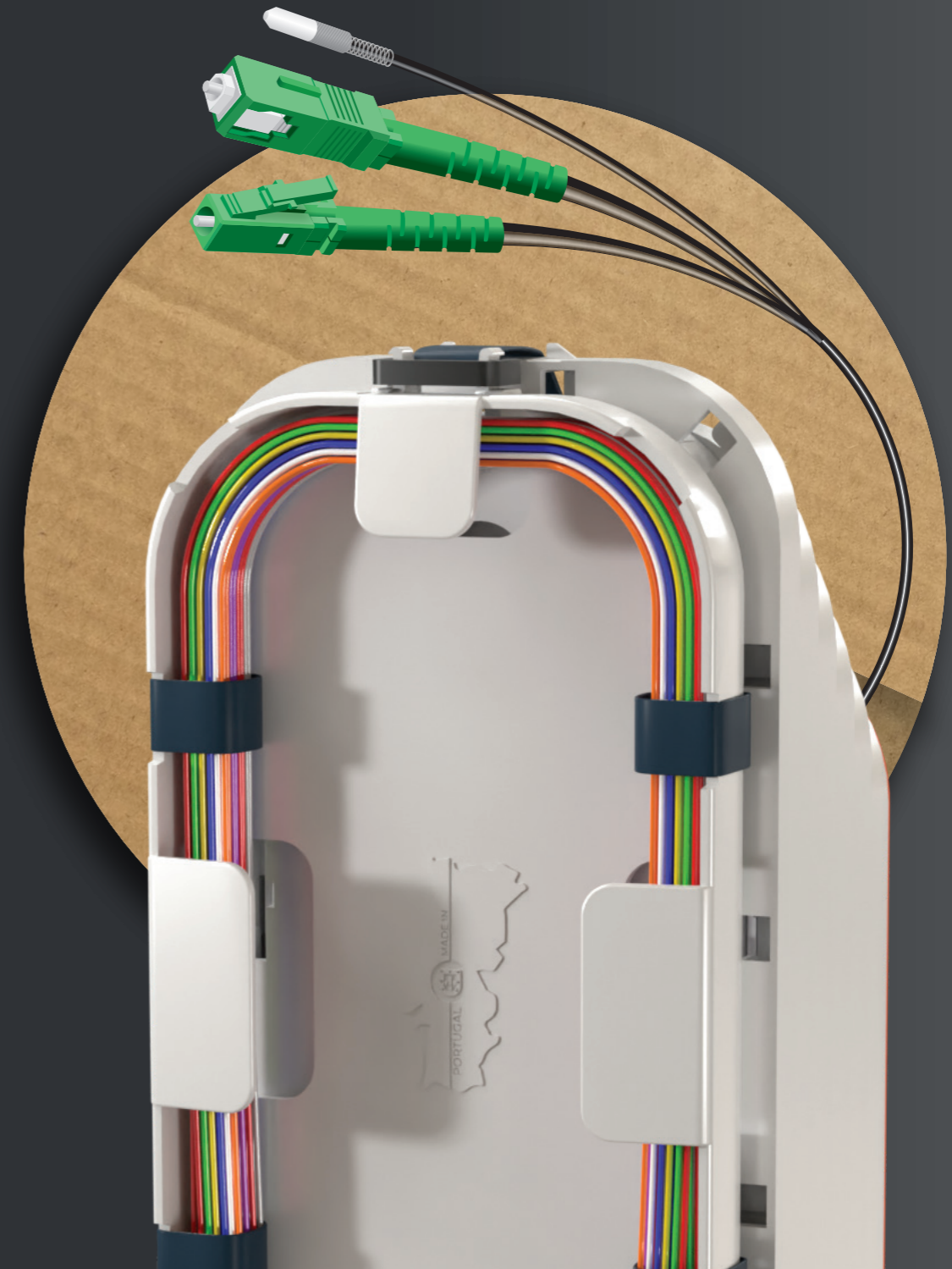

PORTS & SEALS

We are enabling Technicians for **Future-Ready** Networks.

Seal cable & microduct entries effortlessly with our range of mechanical gel seals, or heatshrink if preferred. Our all inclusive kits streamline cable preparation and installation, providing technicians with a hassle free solution for both current needs and future expansion.

Stay ahead of the curve with EM-Finity, ensuring efficient and adaptable networks for years to come.

- 1**  Oval port for 5-12mm cables
- 2**  8 x 4-6mm
-  12 x 5mm
- 2**  6 x 6-8mm
-  2 x 8-10mm, 2 x 10-12mm

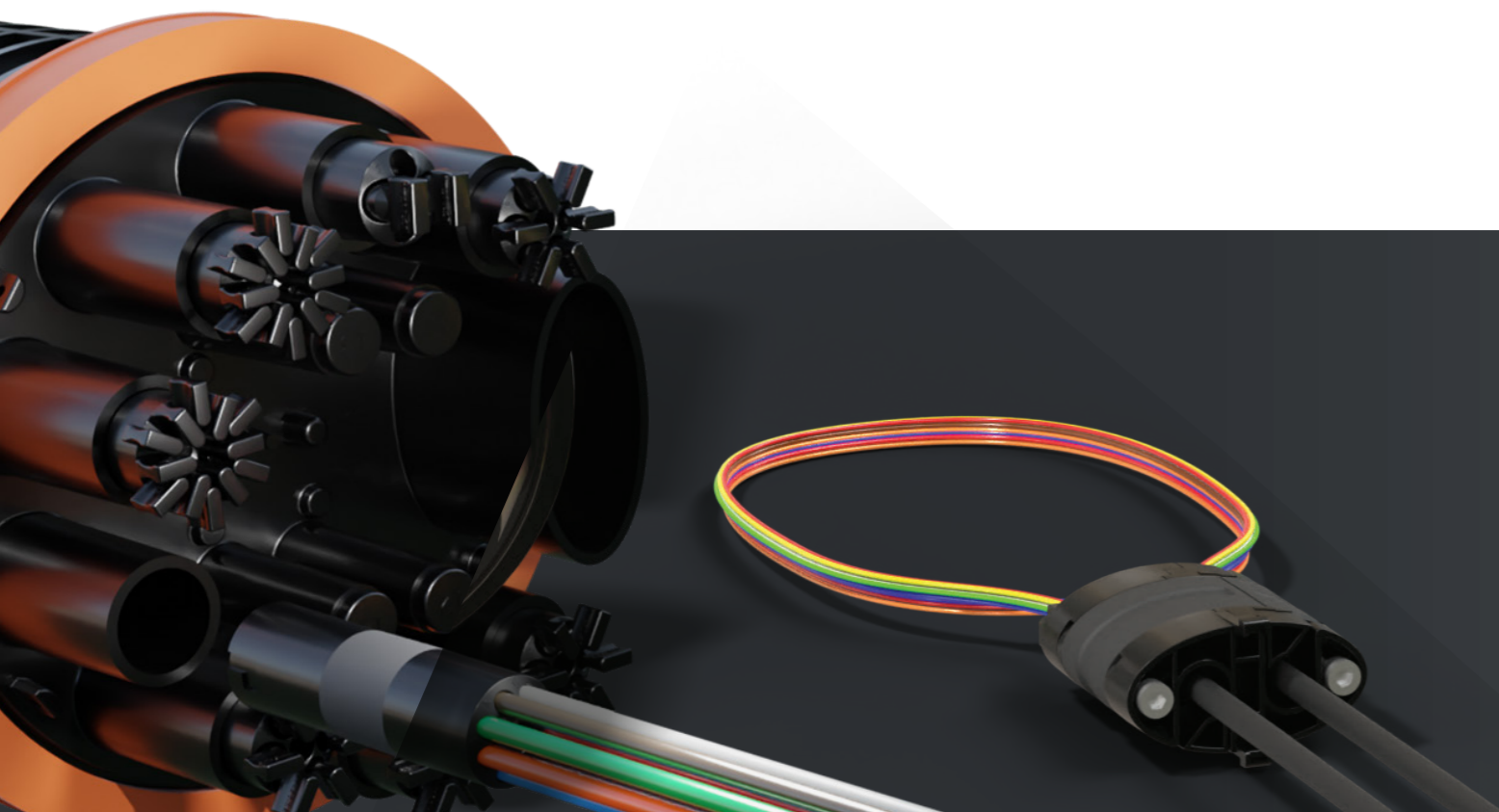

EXPANSION KIT

Increase capacity by **384 splices**

Your gateway to transformative **network expansions**.

The small, medium & large (splice only) closures can be expanded to accommodate more fusion splices or splitters. Simply add our unique expansion ring and then install the modules with the relevant number of trays to configure it your way.

Expansion Kit: Available to increase number of splices by 384 splices per expansion kit or increase Pre-connectorized customer drops (Maximum 96).



FTTH FULL SOLUTION

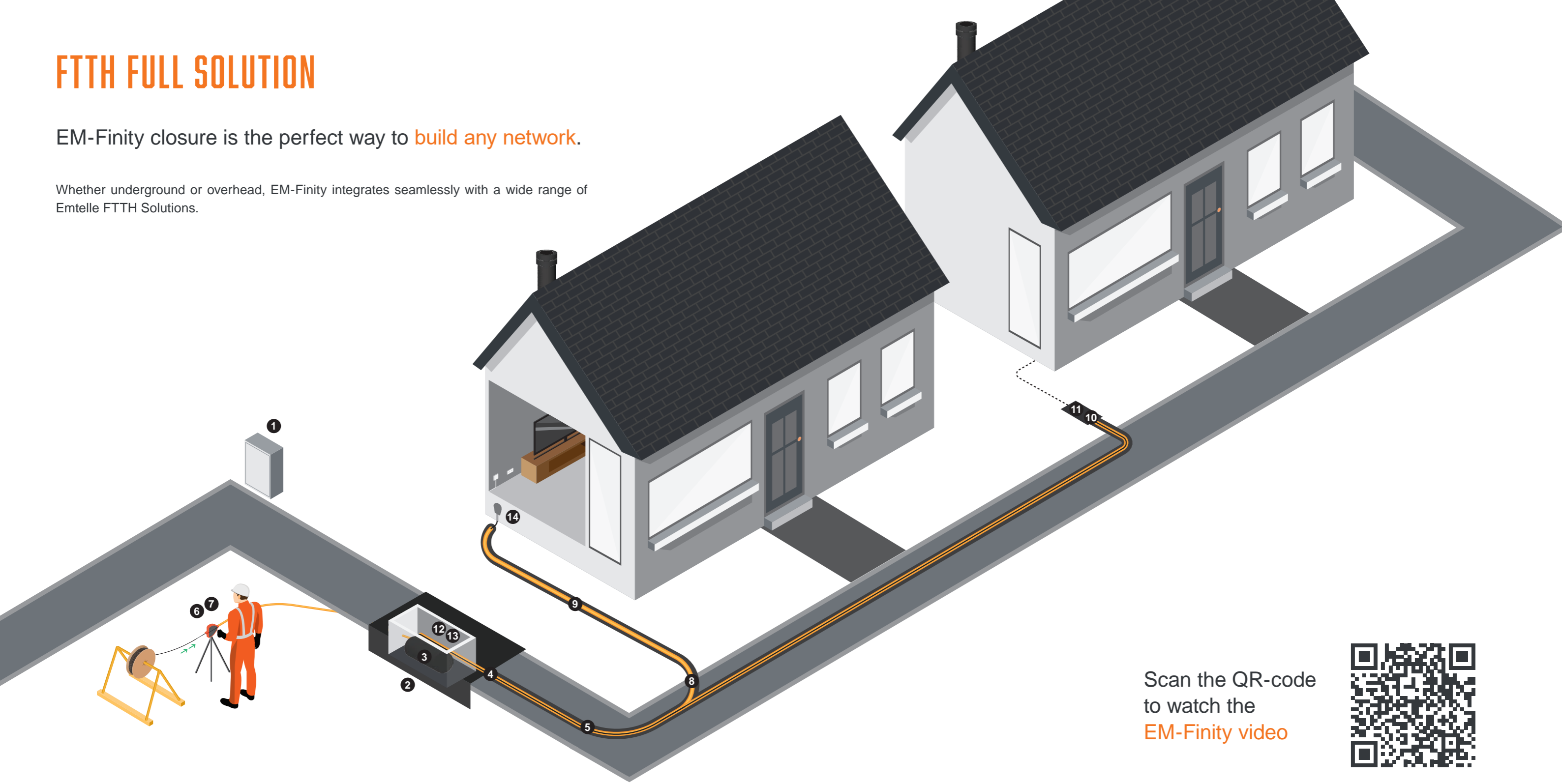

EM-Finity closure is the perfect way to **build any network**.

Whether underground or overhead, EM-Finity integrates seamlessly with a wide range of Entelle FTTH Solutions.



Scan the QR-code to watch the **EM-Finity video**

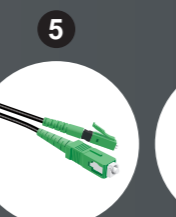

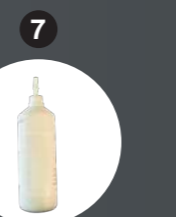
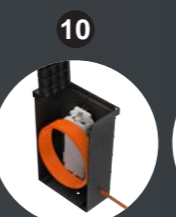
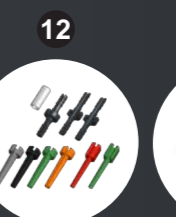
- | | | | | | | | | | | | | | |
|---|---|---|---|--|---|---|---|---|---|---|---|---|---|
|  |  |  |  |  |  |  |  |  |  |  |  |  |  |
| Cabinet | Vault | EM-Finity Closure | Microduct / Tube Bundle | QWK REVOLink3 | DropDrive | Lubricant | EM-Bend | Universal Drop Tube | Toby Box+ | EM-Marker | ELF | Connector | Trunking |

FULL SOLUTION OVERVIEW

Recommended Products

Our solutions are made to perfectly complement your network installations, working together seamlessly for optimal performance.



Cabinet - Suitable for dense distribution of customer connections and large distribution cables. Customer connections can be directly spliced or distributed through the LGX splitter modules.



Vaults have been designed for both sidewalk and roadway installations where they provide access to underground conduit, microduct and splice closures.



Universal Drop Tube is used as a customer drop tube for a variety of installations – it can be used overhead, in duct, along walls or directly buried. With GRP strength members in the wall, the Universal Drop Tube is spade resistant.



Toby Box+ is a compact access point from where a technician can easily maintain and install customer connection infrastructure. It can be used to store excess cable slack or fit a compact splice closure.



EM-Finity Lite has the capability to have either 144 splices, or 12 SC or 24 LC pre-connectorized customers.

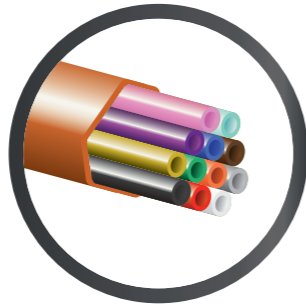

Tube Bundles each boasting microducts with low friction performance. With a robust, thin & tough sheath that envelops each tube bundle, ensuring unmatched protection and durability.



EM-Marker is a compliant telecommunication underground marker that is placed underground to easily trace key points of infrastructures. Other uses include being used as an end cap or with the EM-Bend.



Emtelle Fiber Lock System to eliminate lateral movement of terminated microcables due to vibration or thermal expansion / contraction of the duct system. Design specifically for Emtelle FiberFlow products.

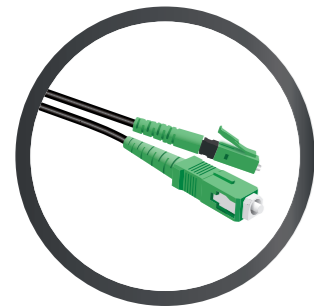

QWKREVOLink3 is a pre-connectorized fiber drop cable for FTTx installation. Streamlining the installation process and considerably lowering the capital expenditure typically required for installation equipment.

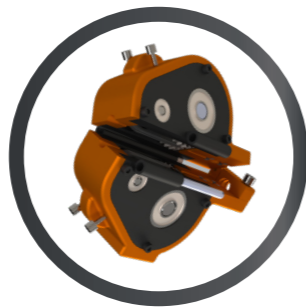

DropDrive Emtelle's cutting-edge drill-assisted pushing machine designed to seamlessly enhance fiber optic pushing installations. Making fiber drop solutions available to the masses.



Push-fit Connectors are suitable for use with FiberFlow microducts of the same size. They ensure a seamless and airtight connection when blowing fiber cable at up to 15 bar working pressures.

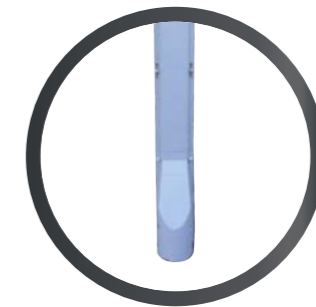

External Customer Lead In and through wall protection of fiber optical customer drop cable.



Lubricant reduces frictional drag during the blowing of small diameter fiber optic minicables into microducts.



EM-Bend product is designed to be quick and easy to install only using cable ties. It offers a smooth 90° bend while protecting the tube connector for optimal cable blowing performance. Can also be used as an L/T-branch.



CONTACT US

Emtelle Group

Allan House, Floor 4
25 Bothwell Street
Glasgow, G2 6NL
United Kingdom

 **+44 (0) 1450 364 000**
 **info@emtelle.com**

Emtelle Hawick, UK

Haughhead
Hawick
TD9 8LF
United Kingdom

 **+44 (0) 1450 364 000**
 **info@emtelle.com**

Emtelle Jedburgh, UK

Oxnam Rd
Jedburgh
TD8 6NN
United Kingdom

 **+44 (0) 1450 364 000**
 **info@emtelle.com**

Emtelle Ridgemount Technologies Ltd

Unit 5, Field Farm
Business Centre,
Launton, OX26 5EL
United Kingdom

 **+44 (0) 1869 277 233**
 **ridgemount.info@emtelle.com**

Emtelle Scandinavia

Vardevej 140
7280 Sønder Felding
Denmark

 **+45 86 28 84 88**
 **salg@emtelle.com**

Emtelle GmbH

An der Flurscheide 20
99098 Erfurt
Germany

 **+49 (0) 361 654 330**
 **info-de@emtelle.com**

Emtelle UAE

Plot KHIA8-126, 127, 128
Taweelah
Abu Dhabi
UAE

 **+971 4 883 1608**
 **info@emtelle.com**

Emtelle USA

101 Mills Gap Rd
Unit A, Fletcher
NC 28732
USA

 **+1 (828) 7079970**
 **info@emtelle.com**

