

## UK\_DS\_Rapid-Stor



### Product Description

---

The Rapid-Stor is a multi-purpose bracket designed to manage cable slack, enclosure fixation and aerial cable hardware attachment in a small footprint. Manufactured from UV stable material the Rapid-Stor is fit for outdoor life. The Rapid-Stor purposefully organizes network poles to reduce clutter and unsightly cable management yet increasing the rate of deployment significantly enough to reduce total cost of implementation. Rapid-Stor can also be deployed in-span with the addition of a suspension clamp.

### Design Features

---

- ⊕ The bracket provides storage for 16 meters (17.5yards) of cable up to a diameter of 10.0mm (0.394") and has sufficient additional capacity to store cables with smaller diameters [ $<5.0\text{mm}(0.197\text{'})$ ] of up to 56 meters (61yards). The Rapid-Stor provides absolute value in FTTx access networks by combining both access network cables as well as customer drop cables in a central storage. There are sufficient slots provided for Velcro or zip tie fixation to keep cable coils organized and attached to the bracket when so required.
- ⊕ The Rapid-Stor's universal mounting plate is fully detachable from the cable storage bracket. Rapid detaching from the bracket increases the value of the equipment or enclosure fixed to the mounting plate as these can now be removed from the pole, for ease of maintenance on the ground, without the need to navigate various process steps or even re-works.
- ⊕ Fixation to the mounting plate is as simple as using the pre-located slots or drilling new holes to fit your bespoke enclosure. The universal mounting plate was engineered with a safe working load of 10kg (22pounds) as attached to the cable bracket.
- ⊕ Rapid-Stor incorporates six D-ring type hard points around its circumference. This negates the need for additional aerial cable hardware, such as monopole suspension brackets and or pigtail bolts, thus effectively reducing clutter on the pole.

This document is intended as a guide only. Whilst the information it contains is believed to be correct, Emtelle can take no responsibility for actions taken based on the information contained in this document. Emtelle reserves the right to make changes to this document without notice. Purchase of Emtelle products does not convey any licence under patents or other intellectual property rights owned by third parties. All sales of product are subject to Emtelle's terms and conditions of sale only, which can be found on Emtelle's website. This document is protected by copyright (c) Emtelle Group [2023]. The products depicted are protected by intellectual property rights. Any unauthorized copying of this document or of our products is prohibited and Emtelle UK Limited will take action to prevent any infringement of its rights and to claim damages for the loss that it suffers. [www.emtelle.com](http://www.emtelle.com)

## UK\_DS\_Rapid-Stor

- ⊗ Rapid-Stor consists of a maximum (including the D-rings) diameter of 426mm (16.8") and stands approximately 80mm (3.15") off a pole. Two pole braces with integrated steel strap routing secures the Rapid-Stor to a pole with the alternative option to mount using coach screws.
- ⊗ The universal mounting plate is shaped as a hexagon and measures 242 x 261 mm (9.5 x 10.3")(hwx)
- ⊗ Three claws retain the main cable coil while smaller diameter cable will be nestled behind the universal mounting plate.

### General Specification

Dimensions	
Required Space	Length = 430mm
	Width = 430mm
	Depth = 105mm
Capacity	
10mm Cable	16m
<5.5mm Cable	52m
Incoming & Outgoing Cable Management	6 x Integral D-rings
Mounting	
Pole	Steel Strapping
	Lag Bolt
Wall	Bolts
Standards	
Operating temperature	-20°C to +50°C
Material	UV Stabilized ASA

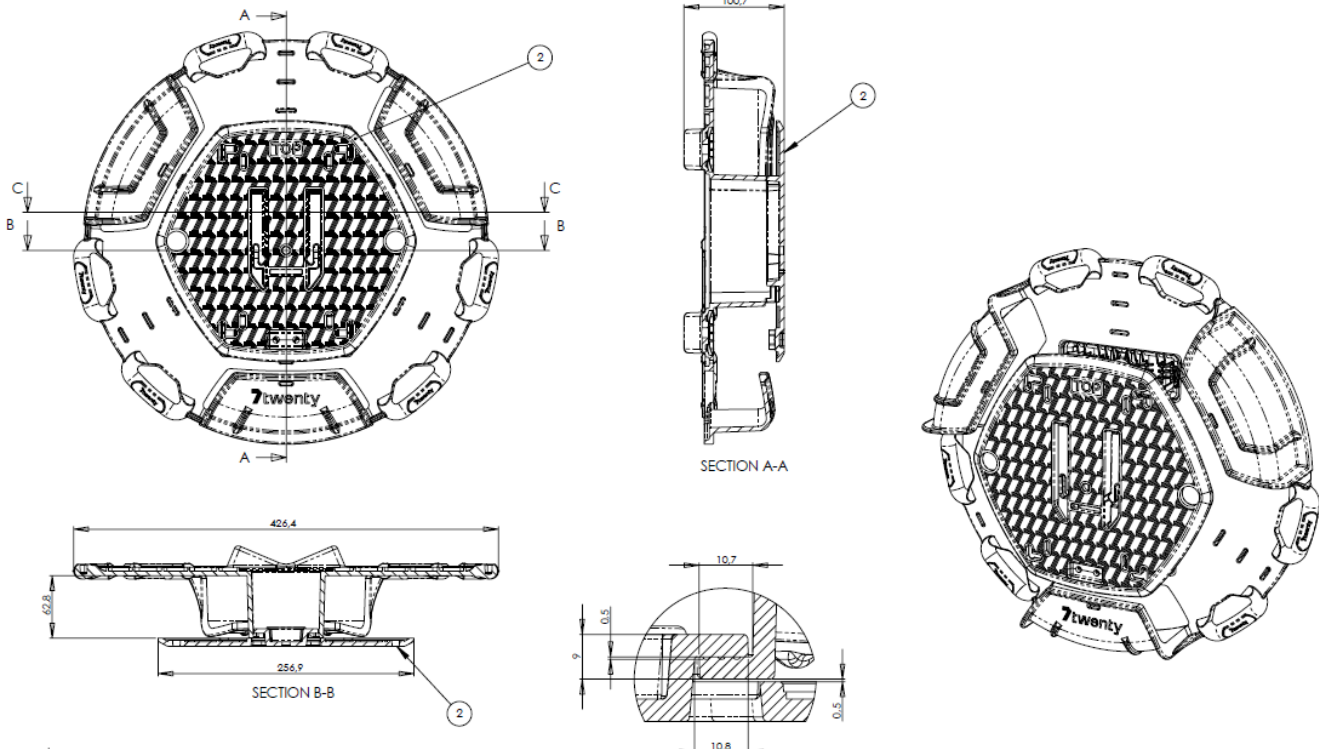

This document is intended as a guide only. Whilst the information it contains is believed to be correct, Emtelle can take no responsibility for actions taken based on the information contained in this document. Emtelle reserves the right to make changes to this document without notice. Purchase of Emtelle products does not convey any licence under patents or other intellectual property rights owned by third parties. All sales of product are subject to Emtelle's terms and conditions of sale only, which can be found on Emtelle's website. This document is protected by copyright (c) Emtelle Group [2023]. The products depicted are protected by intellectual property rights. Any unauthorized copying of this document or of our products is prohibited and Emtelle UK Limited will take action to prevent any infringement of its rights and to claim damages for the loss that it suffers. [www.emtelle.com](http://www.emtelle.com)

## UK\_DS\_Rapid-Stor

### Standard Contents

---

1 x Rapid-Stor Body

1 x Equipment Plate

This document is intended as a guide only. Whilst the information it contains is believed to be correct, Emtelle can take no responsibility for actions taken based on the information contained in this document. Emtelle reserves the right to make changes to this document without notice. Purchase of Emtelle products does not convey any licence under patents or other intellectual property rights owned by third parties. All sales of product are subject to Emtelle's terms and conditions of sale only, which can be found on Emtelle's website. This document is protected by copyright (c) Emtelle Group [2023]. The products depicted are protected by intellectual property rights. Any unauthorized copying of this document or of our products is prohibited and Emtelle UK Limited will take action to prevent any infringement of its rights and to claim damages for the loss that it suffers. [www.emtelle.com](http://www.emtelle.com)

## UK\_DS\_Rapid-Stor



**END OF SPECIFICATION**

This document is intended as a guide only. Whilst the information it contains is believed to be correct, Emtelle can take no responsibility for actions taken based on the information contained in this document. Emtelle reserves the right to make changes to this document without notice. Purchase of Emtelle products does not convey any licence under patents or other intellectual property rights owned by third parties. All sales of product are subject to Emtelle's terms and conditions of sale only, which can be found on Emtelle's website. This document is protected by copyright (c) Emtelle Group [2023]. The products depicted are protected by intellectual property rights. Any unauthorized copying of this document or of our products is prohibited and Emtelle UK Limited will take action to prevent any infringement of its rights and to claim damages for the loss that it suffers. [www.emtelle.com](http://www.emtelle.com)